

SPILL STOP VALVE®



Spill Stop Valves are mechanically actuated and designed to have a trouble free performance.

Spill Stop Valves stay open on normal operation, and allows non-hydrocarbon liquids and rainwater to flow. When hydrocarbon liquids are detected by the sensing element the valve will automatically close.

Spill Stop Valves offers the following:

- Quality CNC machined components.
- Easy Installation.
- Reduces cost of maintenance.
- Viton® FKM O-Rings and seals for long service life.
- Protects surrounding soil and ground water from contamination.
- No external services needed to operate.
- Used in many systems that require drainage.
- Floating roof drain system valves can remain open.
- The signal for valve closure has visual indicators and can be fitted with electronic sensors.



RESPONSE TIME FOR VALVE CLOSURE	
PRODUCT	RESPONSE TIME
Gasoline	15.4 Seconds
Light Crude Oil	27.8 Seconds
Kerosene	11.5 Minutes
Med. Crude Oil	48.0 Minutes
Diesel	59.8 Minutes

NOTES ON THE ABOVE RESPONSE TIME

1. The response times are based on a flow rate of 1 Gallon per Hour.
2. Response times indicate average elapsed time from product entry to valve closure.
3. Testing conducted at ambient temperature using 100% concentration of product.
4. Response times will vary, depending upon percentage of hydrocarbon to non-hydrocarbon liquids

Spill Stop Valves are available in 4", 150Lb. flanges. Customizations are available upon request. The stainless steel and aluminum components make the valve lighter with strength and durability for long service life.

Maintenance: We recommend changing the sensing element annually. We also offer a Spill Stop Valve Service Kit for routine maintenance.



PCI
P.O. Box 57
224 E. Mount Pleasant Rd.

Phone: (225)654-6879
www.pcimachine.com

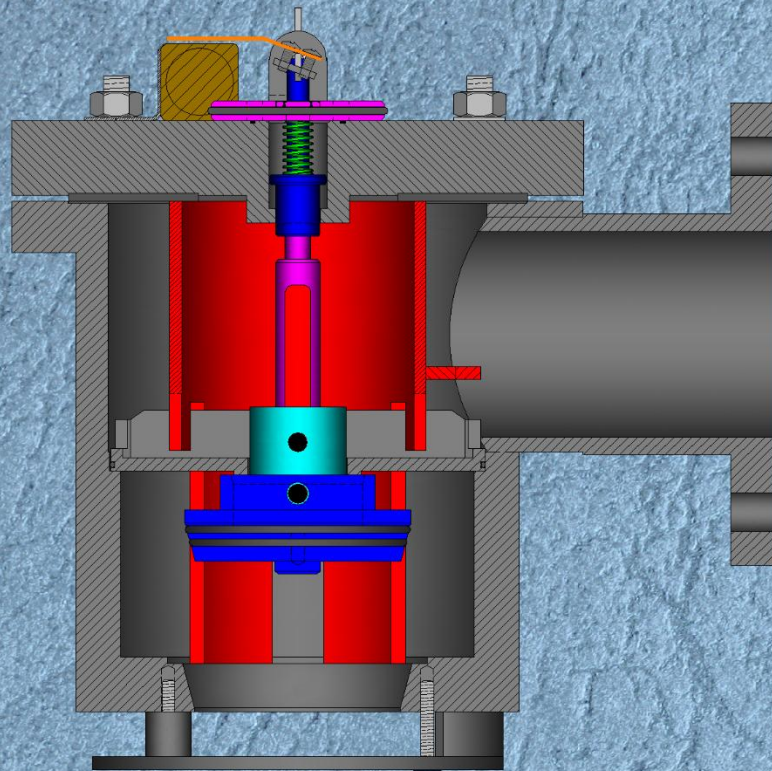

Set / Ready



(Optional) Proximity switch activation.

Plunger falls allowing spring loaded flag to rotate up.

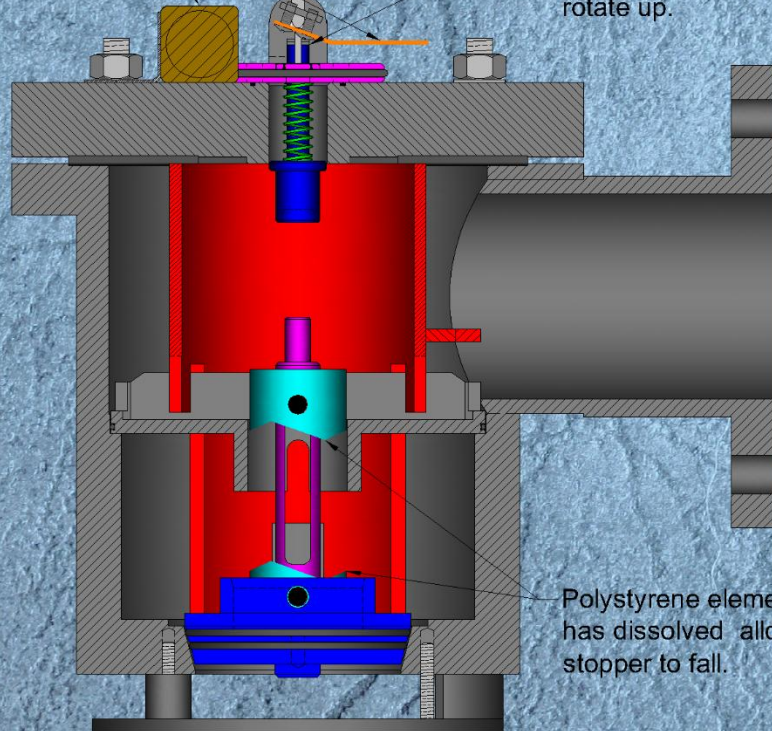

Polystyrene element has dissolved allowing stopper to fall.

Tripped / Activated



PCI
P.O. Box 57
224 E. Mount Pleasant Rd.

Phone: (225)654-6879
www.pcimachine.com

